

INTERNATIONAL STANDARD

ISO 16047

First edition
2005-02-01

Fasteners — Torque/clamp force testing

Éléments de fixation — Essais couple/tension



Reference number
ISO 16047:2005(E)

© ISO 2005

PDF disclaimer

This PDF file may contain embedded typefaces. In accordance with Adobe's licensing policy, this file may be printed or viewed but shall not be edited unless the typefaces which are embedded are licensed to and installed on the computer performing the editing. In downloading this file, parties accept therein the responsibility of not infringing Adobe's licensing policy. The ISO Central Secretariat accepts no liability in this area.

Adobe is a trademark of Adobe Systems Incorporated.

Details of the software products used to create this PDF file can be found in the General Info relative to the file; the PDF-creation parameters were optimized for printing. Every care has been taken to ensure that the file is suitable for use by ISO member bodies. In the unlikely event that a problem relating to it is found, please inform the Central Secretariat at the address given below.

© ISO 2005

All rights reserved. Unless otherwise specified, no part of this publication may be reproduced or utilized in any form or by any means, electronic or mechanical, including photocopying and microfilm, without permission in writing from either ISO at the address below or ISO's member body in the country of the requester.

ISO copyright office
Case postale 56 • CH-1211 Geneva 20
Tel. + 41 22 749 01 11
Fax + 41 22 749 09 47
E-mail copyright@iso.org
Web www.iso.org

Published in Switzerland

Contents

Page

Foreword.....	iv
1 Scope.....	1
2 Normative references	1
3 Terms and definitions.....	2
4 Symbols and their designations.....	3
5 Principle of test	4
5.1 General	4
5.2 Determination of coefficients of friction.....	4
5.3 Determination of torque coefficient K (K -factor).....	5
5.4 Determination of ratio TIF	5
6 Apparatus.....	5
6.1 Testing machine	5
6.2 Test fixture	5
7 Test parts	6
7.1 General	6
7.2 Test-bearing plates or test washers.....	7
7.3 Test nuts for testing bolts, screws and studs.....	8
7.4 Test bolts or test screws for testing nuts.....	8
8 Testing under standard conditions.....	9
9 Testing under specific conditions.....	9
10 Evaluation of results.....	9
10.1 Determination of torque coefficient K	9
10.2 Determination of coefficient of total friction μ_{tot}	10
10.3 Determination of coefficient of friction between threads μ_{th}	10
10.4 Determination of coefficient of friction between bearing surfaces μ_{b}	11
10.5 Determination of yield clamp force F_{y}	11
10.6 Determination of yield tightening torque T_{y}	11
10.7 Determination of ultimate clamp force F_{u}	11
10.8 Determination of ultimate tightening torque T_{u}	11
11 Test report.....	11
11.1 General	11
11.2 Description of fasteners to be tested.....	12
11.3 Description of test parts.....	13
11.4 Testing machine	13
11.5 Test fixture	14
11.6 Environmental conditions	14
11.7 Specific conditions	14
11.8 Test results	14
Bibliography	15

Foreword

ISO (the International Organization for Standardization) is a worldwide federation of national standards bodies (ISO member bodies). The work of preparing International Standards is normally carried out through ISO technical committees. Each member body interested in a subject for which a technical committee has been established has the right to be represented on that committee. International organizations, governmental and non-governmental, in liaison with ISO, also take part in the work. ISO collaborates closely with the International Electrotechnical Commission (IEC) on all matters of electrotechnical standardization.

International Standards are drafted in accordance with the rules given in the ISO/IEC Directives, Part 2.

The main task of technical committees is to prepare International Standards. Draft International Standards adopted by the technical committees are circulated to the member bodies for voting. Publication as an International Standard requires approval by at least 75 % of the member bodies casting a vote.

Attention is drawn to the possibility that some of the elements of this document may be the subject of patent rights. ISO shall not be held responsible for identifying any or all such patent rights.

ISO 16047 was prepared by Technical Committee ISO/TC 2, *Fasteners*, Subcommittee SC 1, *Mechanical properties of fasteners*.

Fasteners — Torque/clamp force testing

1 Scope

This International Standard specifies the conditions for carrying out torque/clamp force tests on threaded fasteners and related parts.

It is applicable, basically, to bolts, screws, studs and nuts made of carbon steel and alloy steel, whose mechanical properties are specified in ISO 898-1, ISO 898-2 or ISO 898-6, having ISO metric threads with thread sizes M3 to M39. It is also applicable to the combination of other externally and internally threaded fasteners with a triangular ISO thread according to ISO 68-1.

It is not applicable to set screws and similar threaded fasteners that are not under tensile stresses, nor to screws which form their own mating thread or threaded fasteners having additional self-locking features.

Unless otherwise agreed, the tests are carried out at room temperature. However, tests carried out under standard conditions are made at a temperature of 10 °C to 35 °C.

This method allows determination of the tightening characteristics of threaded fasteners and related parts.

2 Normative references

The following referenced documents are indispensable for the application of this document. For dated references, only the edition cited applies. For undated references, the latest edition of the referenced document (including any amendments) applies.

ISO 68-1, *ISO general purpose screw threads — Basic profile — Part 1: Metric screw threads*

ISO 273:1979, *Fasteners — Clearance holes for bolts and screws*

ISO 898-1, *Mechanical properties of fasteners made of carbon steel and alloy steel — Part 1: Bolts, screws and studs*

ISO 898-2, *Mechanical properties of fasteners — Part 2: Nuts with specified proof load values — Coarse thread*

ISO 898-6, *Mechanical properties of fasteners — Part 6: Nuts with specified proof load values — Fine pitch thread*

ISO 4014, *Hexagon head bolts — Product grades A and B*

ISO 4017, *Hexagon head screws — Product grades A and B*

ISO 4032, *Hexagon nuts, style 1 — Product grades A and B*

ISO 4033, *Hexagon nuts, style 2 — Product grades A and B*

ISO 4042:1999, *Fasteners — Electroplated coatings*

ISO 16047:2005(E)

ISO 4759-3:2000, *Tolerances for fasteners — Part 3: Plain washers for bolts, screws and nuts — Product grades A and C*

ISO 4762, *Hexagon socket head cap screws*

ISO 6892, *Metallic materials — Tensile testing at ambient temperature*

ISO 7093-1, *Plain washers — Large series — Product grade A*

ISO 8673, *Hexagon nuts, style 1, with metric fine pitch thread — Product grades A and B*

ISO 8674, *Hexagon nuts, style 2, with metric fine pitch thread — Product grades A and B*

ISO 8765, *Hexagon head bolts with metric fine pitch thread — Product grades A and B*

ISO 15071, *Hexagon bolts with flange — Small series — Product grade A*

ISO 15072, *Hexagon bolts with flange with metric fine pitch thread — Small series — Product grade A*

3 Terms and definitions

For the purposes of this document, the following terms and definitions apply.

3.1

clamp force

F

axial tension acting on the bolt shank or compression acting on the clamped member during tightening

3.2

yield clamp force

F_y

clamp force at which the bolt shank or the engaged thread yield under combined stress condition in tightening

3.3

ultimate clamp force

F_u

maximum clamp force under combined stress condition potentially induced before bolt shank fracture

3.4

tightening torque

wrenching torque

applied torque

T

overall torque applied on nut or bolt head in tightening

3.5

yield tightening torque

T_y

tightening torque with which yield clamp force is gained

3.6

thread torque

T_{th}

torque acting on bolt shank through mating threads during tightening

3.7**bearing surface friction torque** T_b

torque acting on clamped member through bearing surfaces during tightening

3.8**ultimate tightening torque** T_u

tightening torque with which ultimate clamp force is gained

4 Symbols and their designations

See Table 1.

Table 1 — Symbols and their designations

Symbol	Designation
d	Nominal thread diameter
d_2	Basic pitch diameter of thread
d_4	Diameter of hole of test fixture
d_h	Clearance hole diameter of washer or bearing part (nominal value)
D_b	Diameter of bearing surface under nut or bolt head for friction (theoretical or measured)
D_o	Outer diameter of bearing surface, $d_{w \min}$ or $d_{k \min}$ (see product standards)
D_p	Diameter of plain area of bearing plate
F	Clamp force
F_p	Proof load according to ISO 898-1, ISO 898-2 or ISO 898-6, whichever is relevant
F_u	Ultimate clamp force
F_y	Yield clamp force
h	Thickness of test-bearing plate or test washer
K	Torque coefficient, $K = \frac{T}{Fd}$
L_c	Clamp length
L_t	Length of complete thread between bearing surfaces
P	Pitch of the thread
T	Tightening torque
T_b	Bearing surface friction torque
T_{th}	Thread torque
T_u	Ultimate tightening torque
T_y	Yield tightening torque
θ	Rotation angle
μ_b	Coefficient of friction between bearing surfaces under nut or bolt head
μ_{th}	Coefficient of friction between threads
μ_{tot}	Coefficient of total friction

5 Principle of test

5.1 General

A tightening torque is steadily applied to a bolt/nut or screw/nut assembly to generate a clamp force, and to measure and/or determine one or more of the tightening characteristics, which can include torque coefficient, coefficient of total friction, coefficient of friction between threads, coefficient of friction between bearing surfaces, yield clamp force, yield tightening torque, rotation angle and ultimate clamp force. In the range of elastic deformation, a linear relationship is assumed between torque and clamp force.

NOTE For studs, only the coefficient of friction between threads is determined.

There are two different goals for testing:

- a) testing of tightening characteristics of a fastener under standard conditions (see Clause 8), i.e. with test-bearing plates/test washers type HH or type HL as specified in 7.2.2 and 7.2.3 and with test nuts or test bolts as specified in 7.3 and 7.4;
- b) testing of tightening characteristics of fasteners under specific conditions, see Clause 9.

The relationship between tightening characteristics which may be obtained and the parameters to be measured are shown in Table 2.

There are different methods (see 5.2 to 5.4) to describe the torque/clamp force behaviour of bolted joints with different surface and lubrication conditions.

Table 2 — Parameters to be measured to obtain respective tightening characteristics

Tightening characteristics which may be determined	Parameters to be measured					Clause
	Clamp force <i>F</i>	Tightening torque <i>T</i>	Thread torque <i>T_{th}</i>	Bearing surface friction torque <i>T_b</i>	Rotation angle <i>θ</i>	
Torque coefficient, <i>K</i>	○	○	—	—	—	10.1
Coefficient of total friction, <i>μ_{tot}</i>	○	○	—	—	—	10.2
Coefficient of friction between threads, <i>μ_{th}</i>	○	—	○	—	—	10.3
Coefficient of friction between bearing surfaces, <i>μ_b</i>	○	—	—	○	—	10.4
Yield clamp force, <i>F_y</i>	○	—	—	—	○	10.5
Yield tightening torque, <i>T_y</i>	○	○	—	—	○	10.6
Ultimate clamp force, <i>F_u</i>	○	—	—	—	—	10.7
Ultimate tightening torque, <i>T_u</i>	○	○	—	—	—	10.8

5.2 Determination of coefficients of friction

To describe the most general conditions of friction without reference to the shape and dimensions of the fasteners, it is useful to determine the different coefficients of friction (see 10.2 to 10.4). The coefficient of friction is a dimensionless number, calculated from measured physical characteristics, which depends on the kind and on the geometry of the surfaces in contact. The necessary measurements are relatively expensive due to the necessity of having sensors for the clamp load and for at least two different torques, and the need to have knowledge about all relevant geometrical dimensions (*d₂*, *P*, *D_b*). The determined coefficients of friction can be used in torque/clamp force calculations for all dimensional ranges of fasteners with the same frictional conditions.

5.3 Determination of torque coefficient K (K -factor)

The measurement is simpler if the torque coefficient K is determined, this being calculated by the formula $K = T/(Fd)$ (see 10.1). In this case, there is a reference to the dimension d . This means that the validity of the K -factor is limited to one dimension. For the determination, it is necessary to measure the clamp force F and the tightening torque T . The K -factor can be used in torque/clamp force calculations only for fasteners with the same frictional conditions, the same dimension d and the same geometric proportion.

5.4 Determination of ratio T/F

The most simple but also most limited method is to measure the pure torque/clamp force relationship. The ratio T/F is only valid for the very special joint investigated. There is no need for knowledge of dimension or shape of the fasteners.

6 Apparatus

6.1 Testing machine

The testing machine shall be capable of applying tightening torque and rotation on nut, bolt head or screw head either automatically or manually, and shall be equipped with a device for measuring the items shown in Table 2 to within an accuracy of $\pm 2\%$ of the values to be measured, unless otherwise specified. The accuracy of angle measurement shall be $\pm 2^\circ$ or $\pm 2\%$ of the measured value, whichever is the greater. For referee purposes, the tightening shall be carried out using a controlled power tool with a constant speed of rotation. The results shall be recorded electronically.

It is important that the stiffness of the testing machine, including load cells and test fixture, be constant throughout the test.

6.2 Test fixture

The test fixture shall be capable of withstanding the combination of clamp force and bearing-surface friction torque without measurable permanent deformation or displacement. Figure 1 gives basic requirements for test fixtures.

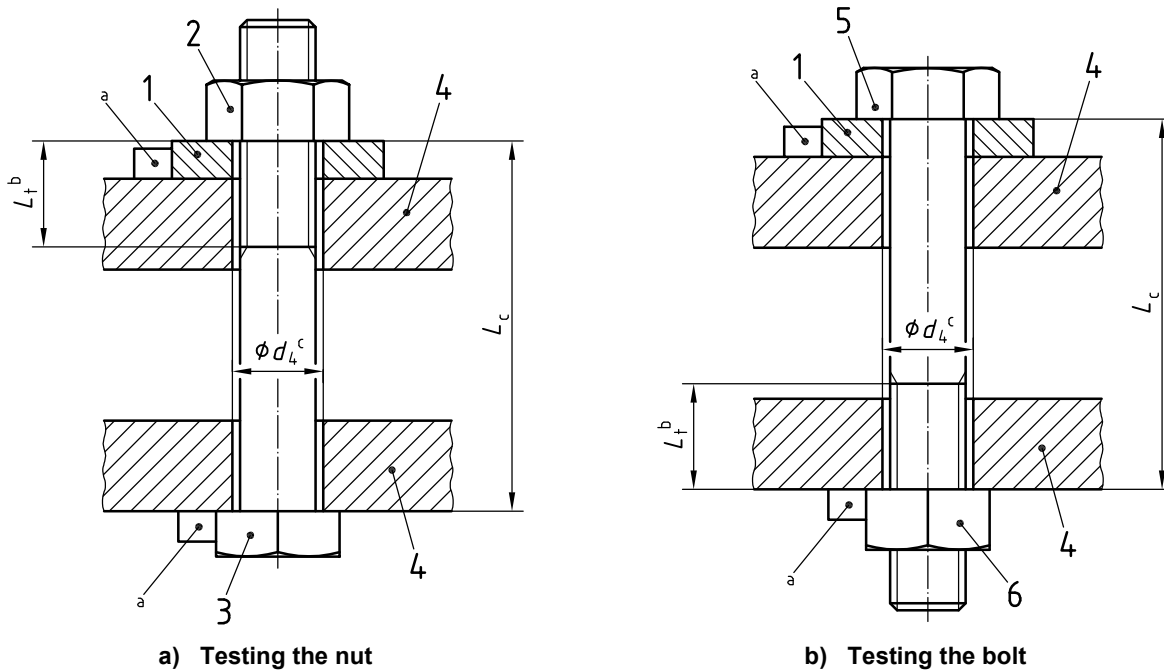

For testing studs, a fixture and setup of test specimen similar to a) is used. However, only the nut end should be tested. Before testing, the metal end of the stud shall be prevented from rotating.

Key

- 1 test-bearing plate, test washer or specified washer
- 2 nut to be tested
- 3 test bolt (or test screw)
- 4 test device (clamped member)
- 5 bolt (or screw) to be tested
- 6 test nut
- a Test-bearing plate or test washer and bolt head or nut shall be fixed by suitable means to prevent rotation and shall be aligned.
- b L_t^b should be at least $1d$ in the case of yield tightening or tightening to the ultimate clamp force.
- c d_4 shall be in accordance with ISO 273:1979, fine series.

Figure 1 — Fixture and test set-up

7 Test parts

7.1 General

Test parts are mating parts for the parts to be tested.

For testing bolts, screws or nuts under standard conditions, specified test parts (test washers, test-bearing plates, test nuts, test bolts, test screws) shall be used (see Figure 1). These test parts are specified in 7.2 to 7.4.

All traces of grease, oil or other contaminations shall be removed before testing. The test parts shall be degreased by ultrasonic means and using suitable solutions in accordance with compatible practices required for health and safety. In case of dispute, the degreasing procedure shall be agreed between the contracting parties.

7.2 Test-bearing plates or test washers

7.2.1 Types

Either a test-bearing plate or a test washer of high (through-hardened, type HH) or low (type HL) hardness shall be used.

The supplier shall select the test-bearing plate or test washer and surface condition according to experience, unless otherwise specified by the purchaser at the time of order.

7.2.2 Test-bearing plate or test washer type HH

Hardness: The hardness shall be 50 HRC to 60 HRC.

Roughness: The surface shall have a roughness of $Ra\ 0,5 \pm 0,3$.

Clearance hole: The clearance hole diameter d_h shall be in accordance with ISO 273:1979, medium series, and shall neither be chamfered nor have a countersink.

Thickness: The minimum thickness, h , of the test-bearing plate or test washer shall be in accordance with ISO 7093-1.

Thickness variation Δh on the same part: See Table 3; for the definition of thickness variation Δh on the same part, see ISO 4759-3.

Flatness: The flatness shall be according to the requirements of ISO 4759-3:2000, product grade A.

Surface condition:

- a) plain surface uncoated and degreased;
- b) zinc electroplated A1J according to ISO 4042 and degreased.

The part shall be free of burrs.

For the basic dimensions of the test-bearing plate or test washer, see Figure 2.

7.2.3 Test-bearing plate or test washer type HL

Hardness: The hardness shall be 200 HV to 300 HV

Roughness: The surface shall have a maximum roughness of $Ra\ 1,6$ for thickness ≤ 3 mm, and $Ra\ 3,2$ for thickness ($3 < h \leq 6$) mm, according to ISO 7093-1.

Clearance hole: The clearance hole diameter d_h shall be in accordance with ISO 273:1979, medium series, and shall neither be chamfered nor have a countersink.

Thickness: The minimum thickness h of the test-bearing plate or test washer shall be in accordance with ISO 7093-1.

Thickness variation Δh on the same part: See Table 3; for the definition of thickness variation Δh on the same part, see ISO 4759-3.

Flatness: The flatness shall be according to the requirements of ISO 4759-3:2000, product grade A.

Surface condition:

- a) plain surface uncoated and degreased;
- b) zinc electroplated A1J according to ISO 4042 and degreased.

The part shall be free of burrs.

For the basic dimensions of the test-bearing plate or test washer, see Figure 2.

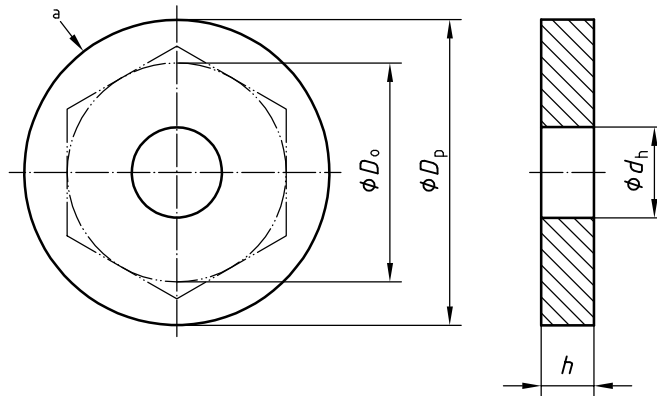

- a The outer contour of the test-bearing plate or test washer is not specified. It shall, however, have a plain surface with a diameter D_p larger than the outer diameter D_o of the bearings surface of the bolt, nut or washer of the screw and washer assembly to be tested.

Figure 2 — Test-bearing plate/test washer types HH and HL

Table 3 — Thickness variation Δh at the same part

Dimensions in millimetres

d	3 to 5	6 to 10	12 to 20	22 to 33	36
Δh	0,05	0,1	0,15	0,2	0,3

7.3 Test nuts for testing bolts, screws and studs

For testing bolts, screws and studs of property class 10.9 and below, the test nut shall be in accordance with ISO 4032 or ISO 8673, property class 10. For testing bolts, screws and studs of property class 12.9, the test nut shall be in accordance with ISO 4033 or ISO 8674, property class 12.

Surface condition:

- a) plain surface uncoated and degreased;
- b) zinc electroplated A1J according to ISO 4042 and degreased.

In the case of short screws or for testing the nut end of studs, replace the test nut by a block with a tapped hole; the length of the engaged thread shall be at least $0,8d$.

7.4 Test bolts or test screws for testing nuts

For testing nuts, the test bolt or screw shall be in accordance with ISO 4014, ISO 4017, ISO 4762, ISO 8765, ISO 15071 or ISO 15072 and shall have a property class corresponding to the property class of the nut to be tested, which shall be, however, not less than property class 8.8. The thread shall be rolled.

Surface condition:

- a) plain surface uncoated and degreased;
- b) zinc electroplated A1J according to ISO 4042 and degreased.

Depending on the type of nut to be tested, the length of the protrusion of the test bolt or test screw shall be two-to-seven thread pitches when the nut is seated against the test-bearing surface or test washer. The thread length shall be such that a minimum of two full threads are within the clamp length when the nut has been tightened. The test bolt shall have a point that is flat and chamfered. The thread shall be free from burrs and contaminations that might affect the tightening torque.

8 Testing under standard conditions

For this test, a testing machine and a test fixture as specified in 6.1 and 6.2, and test parts according to Clause 7, shall be used.

For referee purposes, parts shall not be tested within 24 hours after coating. The temperature of the test pieces shall be the temperature of the test room.

Unless otherwise specified, test parts (test bolts, test screws, test nuts, test washers and test-bearing plates) shall be used once only. Where a test with reused test-bearing plate is planned and performed, the history of the individual test-bearing plate shall be identified clearly.

Either the head of the test bolt (test screw) or the test nut shall be fixed to one side of the test fixture by any means, and the test-bearing plate or test washer shall be fixed to the other side of the fixture. The specimen shall be assembled in the fixture, and nut or bolt head (screw head) — whichever is free to rotate — shall be driven by applying the tightening torque (see Figure 1).

Test conditions shall be identified clearly (see Clause 11) and the test shall be carried out under uniform conditions. Unless otherwise specified, the tightening speed of rotation shall be 10 r/min to 40 r/min for sizes M3 to M16, and 5 r/min to 15 r/min for sizes greater than M16 and up to M39. The speed of rotation shall be constant.

9 Testing under specific conditions

For this test, a testing machine and a test fixture as specified in 6.1 and 6.2 shall be used. However, the test bolt, test screw or test stud, test nut and test-bearing plate or test washer, as well as the tightening speed, shall be according to the specific conditions agreed between the contracting parties.

If test parts other than those specified in 7.2 to 7.4 are used, they shall be described clearly in the test report.

When testing screw and washer assemblies or nut and washer assemblies, the contracting parties shall agree on all test conditions, e.g. whether the washer is to be fixed during the test.

10 Evaluation of results**10.1 Determination of torque coefficient K**

The torque coefficient is determined from the tightening torque/clamp force relation using the following formula:

$$K = \frac{T}{Fd}$$

Unless otherwise specified, the determination shall include the point with the clamp force at 75 % of the proof load ($0,75 F_p$) of the test part or the part to be tested, whichever is the lower.

10.2 Determination of coefficient of total friction μ_{tot}

The following formulae are based on the formula of Kellermann and Klein ^[1] for the tightening torque T :

$$T = F \times \left[\frac{1}{2} \times \frac{P + 1,154 \times \pi \times \mu_{th} \times d_2}{\pi - 1,154 \times \mu_{th} \times \frac{P}{d_2}} + \mu_b \times \frac{D_o + d_h}{4} \right]$$

The coefficient of total friction μ_{tot} is determined from the tightening torque/clamp force ratio by the approximate formula

$$\mu_{tot} = \frac{\frac{T}{F} - \frac{P}{2\pi}}{0,577 d_2 + 0,5 D_b}$$

where

$$D_b = \frac{D_o + d_h}{2}$$

NOTE The error caused by this approximation is about 1 % to 2 %, which can be neglected for the purpose of this calculation.

If the real (measured) value of D_b is to be used, this shall be agreed between the contracting parties.

The coefficient of total friction is only useful for comparison of different friction conditions of bolted joints. The formula for the coefficient of total friction is based on the assumption that the coefficients of friction between threads and between bearing surfaces are equivalent.

Unless otherwise specified, the determination shall include the point with the clamp force at 75 % of the proof load ($0,75 F_p$) of the test part or the part to be tested, whichever is the lower.

10.3 Determination of coefficient of friction between threads μ_{th}

The coefficient of friction between threads is determined from the thread torque/clamp force relation using the following approximate formula:

$$\mu_{th} = \frac{\frac{T_{th}}{F} - \frac{P}{2\pi}}{0,577 d_2}$$

Unless otherwise specified, the determination shall include the point with the clamp force at 75 % of the proof load ($0,75 F_p$) of the test part or the part to be tested, whichever is the lower.

NOTE The thread torque may be calculated from the measurements of tightening torque and bearing surface friction torque as.

$$T_{th} = T - T_b.$$

10.4 Determination of coefficient of friction between bearing surfaces μ_b

The coefficient of friction between bearing surfaces is determined from the bearing surface friction torque/clamp force relation using the following approximate formula:

$$\mu_b = \frac{T_b}{0,5D_b F}$$

where

$$D_b = \frac{D_o + d_h}{2}$$

for the ring-shaped bearing surfaces in contact. If the real (measured) value of D_b is to be used, this shall be agreed between the contracting parties.

Unless otherwise specified, the determination shall include the point with the clamp force at 75 % of the proof load ($0,75 F_p$) of the test part or the part to be tested, whichever is the lower.

NOTE The bearing surface friction torque may be calculated from the measurements of tightening torque and thread torque as.

$$T_b = T - T_{th}$$

10.5 Determination of yield clamp force F_y

The yield clamp force shall be determined from the clamp force/rotation angle or any other equivalent relationship. There are several methods for determining the yield clamp force and the method to be used shall be agreed between the contracting parties.

10.6 Determination of yield tightening torque T_y

The yield tightening torque shall be determined by reading the tightening torque at the point at which the yield clamp force is gained. There are several methods for determining the yield tightening torque and the method to be used shall be agreed between the contracting parties.

10.7 Determination of ultimate clamp force F_u

The ultimate clamp force shall be determined by reading the maximum clamp force achieved during test. The test should be continued until the threaded fastener fails, but if stripping is likely to occur, the test should be stopped immediately after reaching the maximum clamp force, since the stripped fasteners cannot easily be removed from test fixtures.

10.8 Determination of ultimate tightening torque T_u

The ultimate tightening torque shall be determined from the tightening torque/clamp force or any other equivalent relationship by reading the tightening torque at the point at which the ultimate clamp force is gained. The test should be continued until the threaded fastener fails, but if stripping is likely to occur, the test should be stopped immediately after reaching the maximum tightening torque, since the stripped fasteners cannot easily be removed from test fixtures.

11 Test report

11.1 General

In reporting tightening performance data, the test conditions shall be clearly defined and the test report shall include the following information. Deviations from this International Standard shall be indicated clearly.

11.2 Description of fasteners to be tested

11.2.1 Bolts, screws and studs

Mandatory information:

- a) designation for standardized fasteners;
- b) calculated value of D_b ;
- c) type, property class, thread size, length of fastener for non-standardized fasteners;
- d) surface coating;
- e) lubricant;
- f) manufacturing method of thread.

Information if required:

- g) actual mechanical properties (tensile strength or hardness);
- h) surface roughness;
- i) manufacturing method of fastener;
- j) any other information.

11.2.2 Nuts

Mandatory information:

- a) designation for standardized fasteners;
- b) calculated value of D_b ;
- c) type, property class, thread size, nut height for non-standardized fastener;
- d) surface coating;
- e) lubricant;
- f) manufacturing method of thread.

Information if required:

- g) actual hardness;
- h) surface roughness;
- i) manufacturing method of the fastener;
- j) any other information.

11.2.3 Washers

Mandatory information:

- a) designation for standardized washers;
- b) dimensions and tolerances for non-standardized washers;
- c) surface conditions;
- d) actual hardness.

Information if required:

- e) surface roughness;
- f) manufacturing method;
- g) any other information.

11.3 Description of test parts

11.3.1 Test bolts and test screws

Either

- a description of the test bolt or screw in accordance with 7.4, or
- when tested under specific conditions, a description in accordance with 11.2.1.

11.3.2 Test nuts

Either

- a description of the test nut in accordance with 7.3, or
- when tested under specific conditions, a description in accordance with 11.2.2.

11.3.3 Test-bearing parts

Either

- a description of the test-bearing part in accordance with 7.2, or
- when tested under specific conditions, a description in accordance with 11.2.3.

11.4 Testing machine

The following information shall be given:

- a) capacity;
- b) type of measuring devices and their capacity;
- c) driving speed;
- d) drive (manual or power tool).

11.5 Test fixture

The following information shall be given:

- a) clamp length L_C ;
- b) length of complete thread between bearing surfaces L_t ;
- c) driven member (bolt or nut).

11.6 Environmental conditions

The following information shall be given:

- a) temperature;
- b) air humidity.

11.7 Specific conditions

These shall be as agreed between contracting parties.

11.8 Test results

11.8.1 Measured values

The following information shall be given:

- a) number of samples;
- b) D_b value, if not calculated according to 10.2 or 10.4;
- c) torque at a specified clamp force or clamp force at a specified torque;
- d) rotation angle (if asked for).

11.8.2 Determined values (which one is asked for)

The following information shall be given:

- a) torque coefficient K ;
- b) torque/clamp force relationship TIF or FIT ;
- c) coefficient of total friction μ_{tot} ;
- d) coefficient of friction between threads μ_{th} ;
- e) coefficient of friction between bearing surfaces μ_b .

11.8.3 Other results

The following information shall be given:

- a) results agreed between the contracting parties;
- b) any other observations.

Bibliography

- [1] KELLERMANN, R. and KLEIN, H-C. Investigations on the influence of friction on the clamp force and the tightening torque of bolted joints. R. *Konstruktion*, **2**, 1955. Springer-Verlag. Berlin/Göttingen/Heidelberg

ICS 21.060.01

Price based on 15 pages